



INSTALLATION, OPERATION AND MAINTENANCE INSTRUCTIONS

HDL106 NE- Emergency Luminaires

Inmetro

Important: Please read these instructions carefully before installing or maintaining this equipment. Good electrical practices should be followed at all times and this data should be used as a guide only.

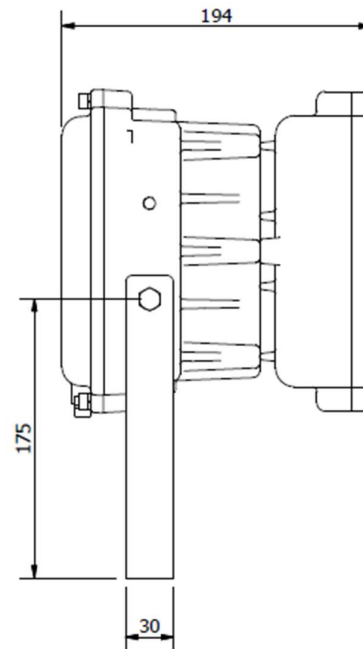
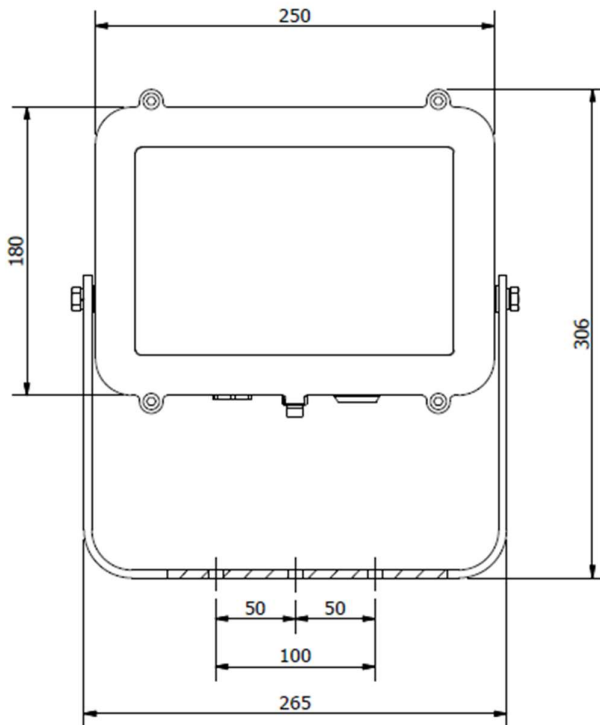

Weight 8kg

Windage – 0.05m²



Tipo de proteção	Ex eb mb (Maior segurança, encapsulamento), Ex tb (poeira)	
Normas de proteção	ABNT NBR IEC 60079-0, 60079-7, 60079-18, 60079-31	
Classificação de área	Áreas Zona 1 e Zona 2 para (ABNT NBR IEC 60079-10) de acordo com instalações segundo a ABNT NBR IEC 60079-14	
Certificado	IEx 18.0173X	
Codificação do equipamento	HDL106NE (duração de 90 minutos, conforme fornecido com a conexão cruzada)	-20 °C ≤ Ta ≤ +55°C. 3h de duração com conexão cruzada removida. (Veja Condições Específicas de Uso N° 10)
	Ex eb mb IIC T4 Gb Ex tb IIIC T103 °C Db IP6X -20 °C ≤ Ta ≤ +50 °C.	
Grau de proteção	IP66/67	
Classe de segurança de laser	Produto LED de classe 1	

SPECIFIC CONDITIONS OF USE (denoted by X after the certificate number).

1. Except for internal wiring, not more than one single or multiple strand lead shall be connected into either side of any terminal, unless multiple conductors have been joined in a suitable manner, e.g. two conductors into a single insulated crimped boot lace ferrule.
2. Leads connected to the terminals shall be insulated for the appropriate voltage and this insulation shall extend to within 1 mm of the metal of the terminal throat.
3. When terminals in accordance with certificate Sira 01ATEX3247U are used, all terminal screws, used and unused, shall be tightened down to between 0.5 Nm and 0.7 Nm.
4. When terminals in accordance with certificate Sira 01ATEX3249U are used, all terminal screws, used and unused, shall be tightened down to between 1.2 Nm and 2 Nm.
5. When terminals in accordance with certificates Sira 01ATEX3247U and Sira 01ATEX3249U are used, they shall only be installed and wired with cable within a temperature range of -10°C to 80°C.
6. When cross-connecting combs are used on terminals to certificates Sira 01ATEX3247U and Sira 01ATEX3249U, the relevant conditions associated with those certificates shall be applied.
7. Cable entry holes shall be fitted with either an appropriately certified cable gland or appropriately certified blanking element. These shall provide and maintain a minimum enclosure ingress protection of IP66 or IP67 as appropriate.
8. If more than 8 individual LEDs are not illuminated, the LED assembly shall be replaced.
9. The supply circuit must be protected by a fuse capable of withstanding a prospective short circuit current of 1500 A.
10. The battery powered emergency versions, are suitable for an ambient temperature range of -20°C to +50°C when installed with the terminal cross-link in accordance with the manufacturer's installation instructions, which achieves a 75% output, i.e. 48 illuminated LEDs. The HDL106NE is suitable for an ambient temperature range of -20°C to +55°C when the terminal cross-link is not installed, which achieves 50% output.
11. When the Lexan polycarbonate lens is fitted, the equipment shall only be used in areas with a low risk of mechanical impact.
12. Under certain extreme circumstances, the non-metallic parts incorporated in the enclosure of this equipment may generate an ignition-capable level of electrostatic charge. Therefore the equipment shall not be installed in a location where the external conditions are conducive to the build-up of electrostatic charge on such surfaces. In addition, the equipment shall only be cleaned with a damp cloth.



1.0 Introduction

The Chalmit HDL106NE range brings to hazardous areas the very latest in lighting technology. It is a compact light source that uses ultra bright light emitting diodes to provide light from mains power. The LEDs are maintenance free and can last up to 150,000 hours @ 25°C ambient. They are housed in an impact and corrosion resistant marine grade aluminium enclosure with a toughened glass or polycarbonate lens. The control gear is electronic with regulated lamp output. The LEDs work equally well at very low temperatures as they do at high and produce a product with very low overall power consumption.

Important:

Electrostatic Charging Hazard: Clean only with a damp cloth, when fitted with a polycarbonate lens.

LED White High Power.

Voltage ranges: 100 – 254V 50/60 Hz

Electrical Operating Data @ 230V 50Hz	<u>48 x LED</u> <u>HDL106NE</u>	<u>96 x LED</u> <u>HDL106NES</u>	<u>96 x LED</u> <u>HDL106NEE</u>	<u>144 x LED</u> <u>HDL106NSE</u>	<u>144 x LED</u> <u>HDL106NESE</u>	<u>144 x LED</u> <u>HDL106NEEE</u>
Power Watts	62W	113W	122W	165W	174W	184W
Current Amps	288mA	525mA	567mA	767mA	809mA	855mA

For lumen output photometric data can be requested.

Power Factor 0.9 minimum

Over voltage 375V

Looping The looping current rating is 12A. 4mm² terminals are standard.

Storage Luminaires are to be stored in cool dry conditions -40°C to +50°C preventing ingress of moisture and condensation. Battery packs in storage should be cycled charged/discharged/charged every 9 months, as per instructions below.
Always disconnect battery plug and socket for storage.
 Any specific instructions concerning emergency luminaires must be complied with.
 (Warning: Battery packs not cycled and stored for a year may not be recoverable)

'IMPORTANT NOTE FOR ALL EMERGENCY UNITS:

Please ensure encapsulated fuse provided in each emergency unit is removed from its packaging and connected between the 2 terminals marked 'BATT +'. Failure to do so will mean luminaire will not operate in emergency mode.'

PAT Testing (Insulation) 500V DC MAX for 1 min

1.0 Installation and Safety

1.1 General

There are no health hazards associated with this product whilst in normal use. However, care should be exercised during the following operations. Installation should be carried out in accordance with *EN/IEC 60079-14* or the local hazardous area code of practice, whichever is appropriate, and fitting of specified insulating material to be adhered to where a specific fire resistance rating is required. In the UK the requirements of the '*Health and Safety at Work Act*' must be met.

Handling and electrical work associated with this product to be in accordance with *the 'Manual Handling Operations Regulations'* and '*Electricity at Work Regulations, 1989*'. Your attention is drawn to the paragraphs (i) 'Electrical Supplies', (ii) 'Electrical Fault Finding and Replacement' and (iii) 'Inspection and Maintenance'.



The luminaires are class 1 and should be effectively earthed. Certification details on the rating plate must be verified against the application requirements before installation.

The information in this leaflet is correct at the time of publication. The company reserves the right to make specification changes as required.

1.2 Use in Combustible Dust Atmospheres

Where the equipment is used in ignitable dust atmospheres reference must be made to the selection and installation standards in order that the equipment is used correctly. In particular this applies to the de-rating of surface temperature for use where dust clouds may be present. Dust layers should not be allowed to accumulate on the surface and good housekeeping is required for safe operation. Dust in layers has the potential to form ignitable clouds and to burn at lower temperatures.

Refer to EN (IEC) 60079-10-2 & EN (IEC) 60079-14 for additional details of selection and installation.

1.3 Hybrid Mixtures – Gas and Dust

Where hybrid mixtures exist as defined in EN 1127 as a potentially explosive atmosphere, consideration should be given to verifying that the maximum surface temperature of the luminaire is below the ignition temperature of the hybrid mixture.

1.4 Tools

5mm Allen Key (Hex)

Spanners for installing cable glands. Pliers, knife, wire strippers/cutters.

1.5 Emergency Duration

The luminaire is supplied set for 90 minutes emergency duration at 75% light output. This is suitable for an ambient of +50°C. This is set by factory installing a wire link between terminals marked Hi/Lo. If this cross link is removed, the luminaire will achieve 35% light output for 3 hours in emergency operation and is suitable for an ambient of +55°C.

(note: on double and triple units, this link will need to be removed in each emergency module to achieve 3 hour duration)

2.0 Electrical Supplies

The standard unit is rated for a nominal 100V-254V AC 50Hz or 60Hz. A maximum voltage variation of +6%/-6% on the nominal is expected. (The safety limit for T rating is +10%). Equipment must not be operated outside of the rated voltage of the control gear. The lamp supply is regulated therefore the light output over the supply range is constant.

3.0 LED Array & Driver

This product is fitted with LEDs that can last up to 150,000 hours @ 25°C ambient. Therefore in many applications replacement of the LED array will be unnecessary. If replacement is required ensure mains supplies are isolated before commencing work. Remove the front cover and then remove the LED array assembly.

Care must be taken when disconnecting and reconnecting wiring.

If required contact Chalmit Technical.

4.0 Mounting

Luminaires should be installed where access for maintenance is practical and in accordance with any lighting design information provided for the installation.

The fitting is supplied with an eye bolt for a safety line.

NOTE: When mounting a triple unit, the 2 outermost and the centre mounting holes must be used to secure the stirrup in place.

5.0 Cabling and Cable Glands

5.1 Cables

The maximum conductor size is 4mm². Internal earth point is provided in the main terminal block. 300/500V cable ratings are adequate and no special internal construction is necessary. The standard looping cable size is up to 4mm². The selection of cable size must be suitable for the fuse rating. Terminals are supplied with suitability for looping. Where looping is used the maximum current is 12A. Terminals are accessed by removing the front cover and LED array. For Maximum cable temperature rise refer to nameplate.



5.2 Cable Glands

The installer and user must take responsibility for the selection of cables, cable glands and seals. Two tapped cable entries are provided, one with a plug and seal suitable for permanent use, the other with a travelling plug not suitable for use in service. Sealing plugs are similarly rated and a tool must be used for their removal. Cable entries are M20x1.5. Cable glands and sealing plugs must have “Generation E” approval.

The cable and gland assembly when installed must maintain the ingress protection rating of the luminaire. The cable glands must be suitable for the application. Where brass cable glands are used in a corrosive environment, cadmium or nickel plating should be used.

6.0 Inspection and maintenance

Visual inspection should be carried out at a minimum of 12 monthly intervals and more frequently if conditions are severe; refer to EN/IEC 60079-17.

7.0 Electrical fault finding and replacement

Any fault finding must be done by a competent electrician with the luminaire isolated and, if carried out with the luminaire in place, under a permit to work. Fault finding is by substitution with known good components.

8.0 Routine Maintenance

Visual tests and checks should be carried out at intervals described by the appropriate regulations, EN/IEC 60079-17, and should include the following:

Check that the LEDs are working.

Check for mechanical damage/corrosion.

Check for loose connections including earthing.

Check for undue accumulations of dust or dirt.

Verification of tightness of fixing, glands, blanking plugs etc. *Torque Values- Stirrup mounting point: 10Nm, Aluminium/Glass Diffuser fixing screws: 4Nm, Polycarbonate Diffuser fixing screws: 1.5 - 2Nm.*

Check for unauthorised modifications.

Check condition of enclosure gasket and fastenings.

Check for any accumulation of moisture.

Periodic inspection of the enclosure seal should be carried out to ensure that the seal is sound.

If the luminaire has been subject to abnormal conditions, for example, severe mechanical impact or chemical spillage, it must be de-energised until it has been inspected by an authorised and competent person. If in doubt, the unit should be returned to Chalmit for examination and, if necessary, replacement.

Before re-assembling, all connections should be checked and any damaged cable replaced.

8.1 Checking of Battery separately

If the battery is to be checked separately, it should be charged using a **constant current charger** at 200/400mA for 30/15 hours for the 7Ah. Discharge measurement is not easy as the current is proportional to the voltage for resistance loads, so it has to be averaged. Discharge the battery at 1 to 2A and multiply current by time. Do not discharge below 1 volt per cell, which is 5V. The capacity should be 75% or more of normal.

9.0 Disposal of Material

The unit is mainly made from incombustible materials. The control gear contains plastic resin and electronic components. All electrical components may give off noxious fumes if incinerated. Take care to render these fumes harmless or avoid inhalation. Any local regulations concerning disposal must be complied with. Any disposal must satisfy the requirements of the WEEE directive [2012/19/EU] and therefore must not be treated as commercial waste.

To comply with the Waste Electrical and Electronic Equipment directive 2012/19/EU the apparatus cannot be classified as commercial waste and as such must be disposed of or recycled in such a manner as to reduce the environmental impact.

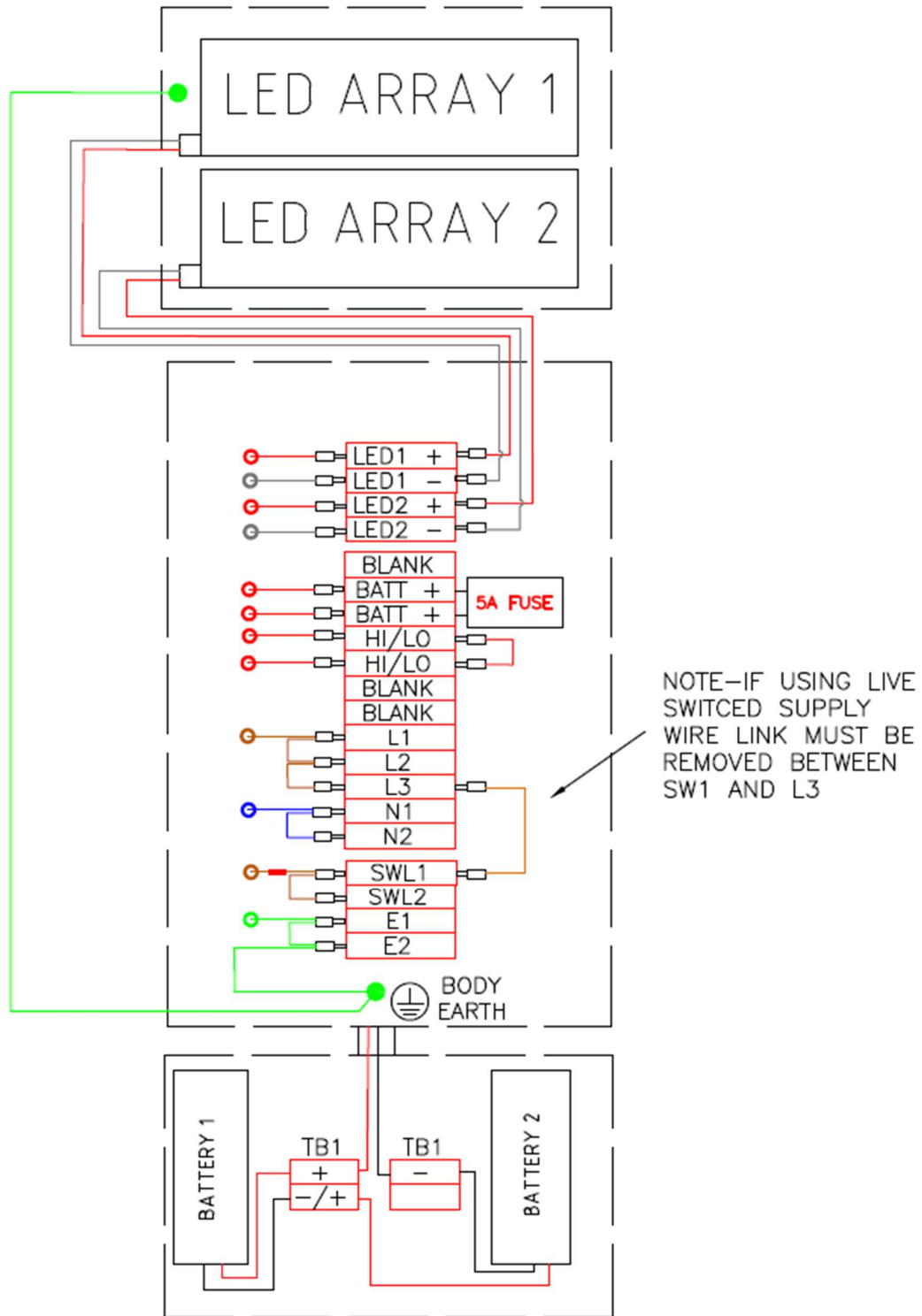



Chalmit Lighting is a leading supplier of Hazardous Area lighting products

	<p><u>CHALMIT LIGHTING</u> PO Box 5575 Glasgow, G52 9AP Scotland</p>	
<p>Telephone: +44 (0) 141 882 5555 Fax: +44 (0) 141 883 3704 Email: info@chalmit.com Web: www.chalmit.com</p>	<p>Registered No: 669157 Registered Office: Cannon Place 78 Cannon Street London EC4N 6AF UK</p>	

For technical support, please contact: techsupport@chalmit.com

Note: Chalmit Lighting reserves the right to amend characteristics of our products and all data is for guidance only.